

Remove wheels,
refer to 36 10 300.

Disconnect handbrake cables from handbrake lever and pull out of guide tubes,
refer to 34 41 120.

On Z3, remove oddments tray and handbrake lever if necessary.

Remove propeller shaft,
refer to 26 11 000.

Pull off speedometer signal plug on final drive.

Disconnect ABS pulse sender.

If necessary, unplug brake pad wear indicator.

If necessary, unfasten stabilizer on semi-trailing arms.

Release pipe on carbon canister.

M Roadster / M Coupé:

Remove brake calipers.

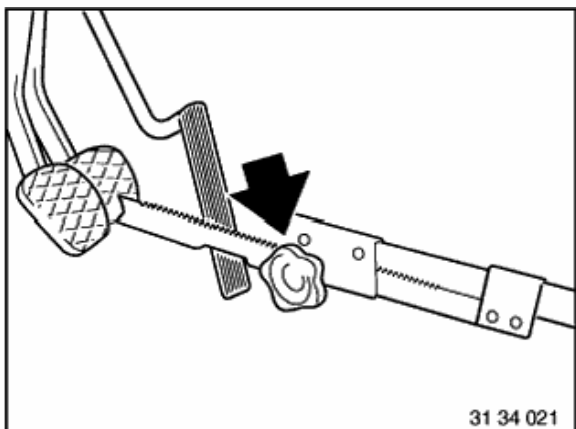

Not M Roadster / M Coupé:

Install pedal support and actuate brake pedal. This prevents brake fluid from escaping from the brake system when the brake line is disconnected.

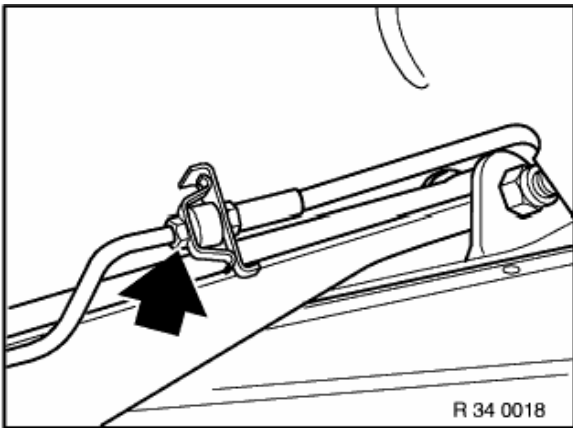

Disconnect left and right brake pipes.

Installation:

Tightening Torque,
refer to Technical Data 34 32 1AZ.
After assembly, bleed brake system,
refer to 34 00 047.

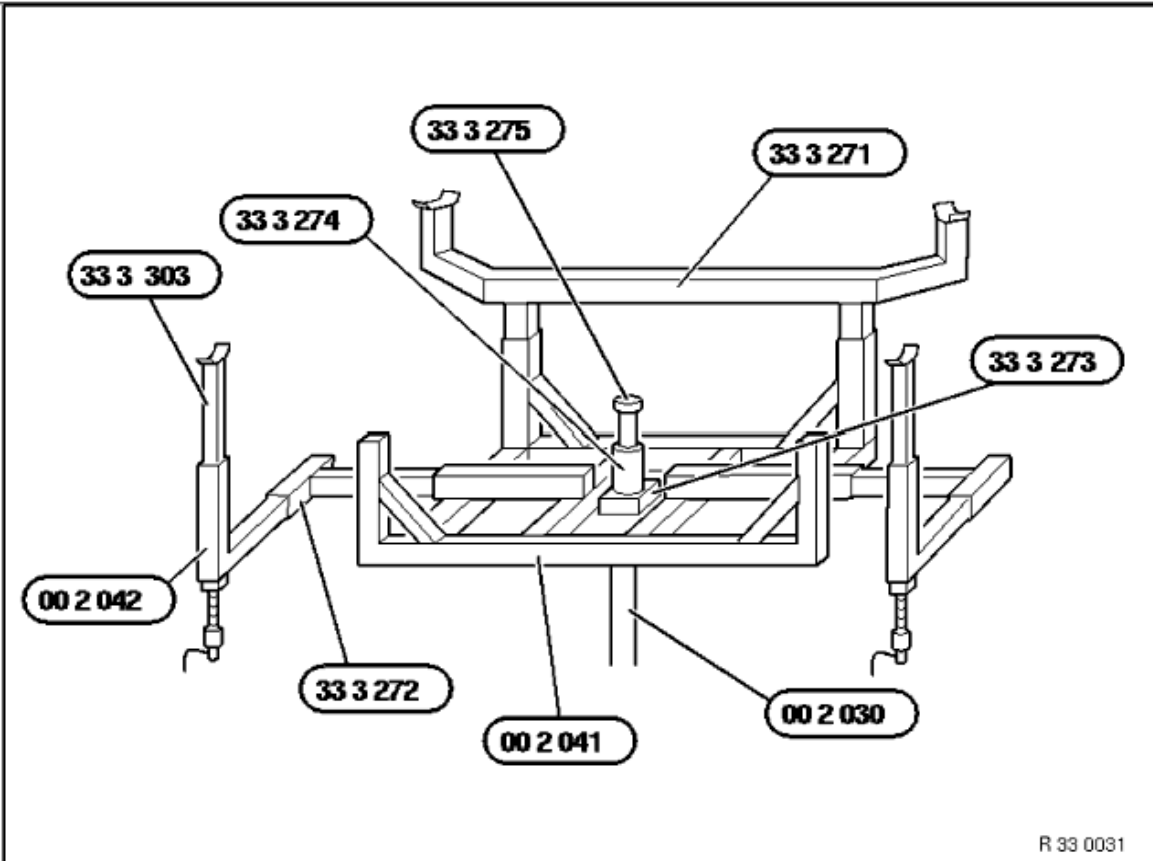

Take up rear axle with special tools 00 2 030/041/042 and 33 3 271/272/273/274/275/303.

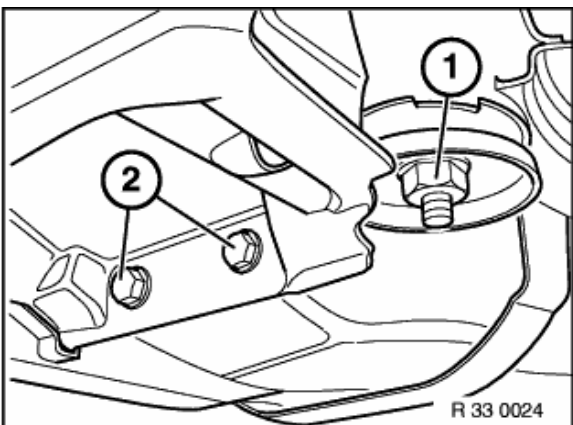

Unscrew nut (1) and bolts (2).

Installation:

Replace self-locking nuts.
Tightening Torque (1),
refer to Technical Data 33 33 3AZ.
Tightening Torque (2),
refer to Technical Data 33 32 17AZ.

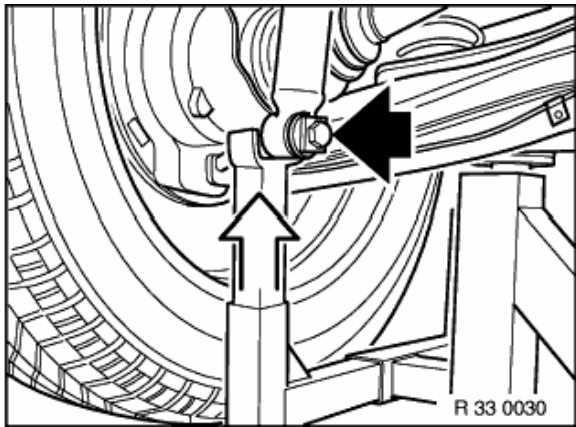

Slightly raise semi-trailing arm, unfasten screw, remove shock absorber and lower semi-trailing arm slightly.

Installation:

Tightening Torque,
refer to Technical Data 33 52 1AZ

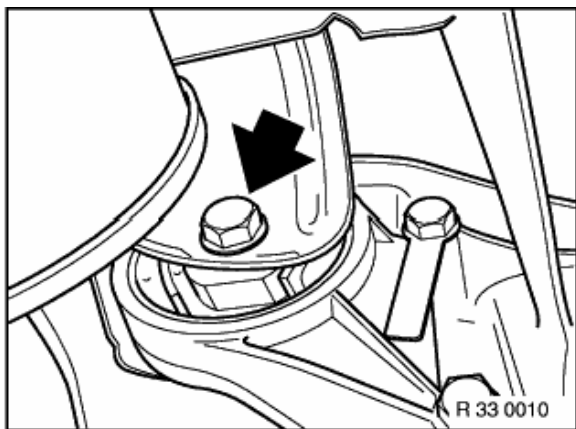

Unscrew screw.

Installation:

Replace self-locking nut.
Tightening Torque,
refer to Technical Data 33 17 4AZ.

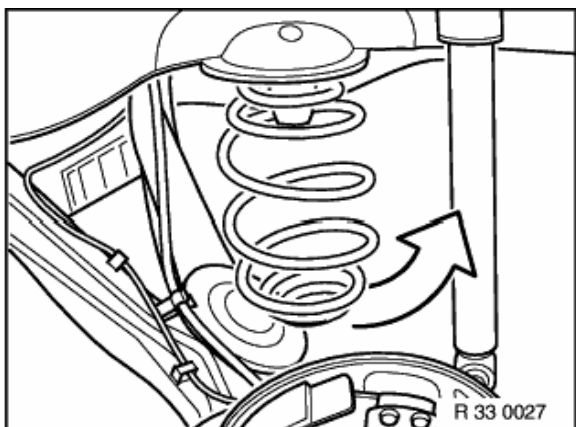

Lower rear axle until coil springs are exposed.
Remove coil springs.
Lower rear axle and drive out.