

Z3

When crossing the border into countries where vehicles drive on the opposite side of the road to the country in which a vehicle is licensed, the asymmetric wedge on the low-beam headlight must be covered.

Caution!

To do so, use only genuine strip supplied by BMW because the reflector is made from plastic and strips with unsuitable glue could damage the reflector. It should be possible to remove the genuine strip without leaving glue residues.

If there are still glue residues, they may only be removed with the cleaning cloth provided or with pure alcohol. Do not under any circumstances use solvents (e.g. paint thinner). This can damage the plastic by discolouring the lens.

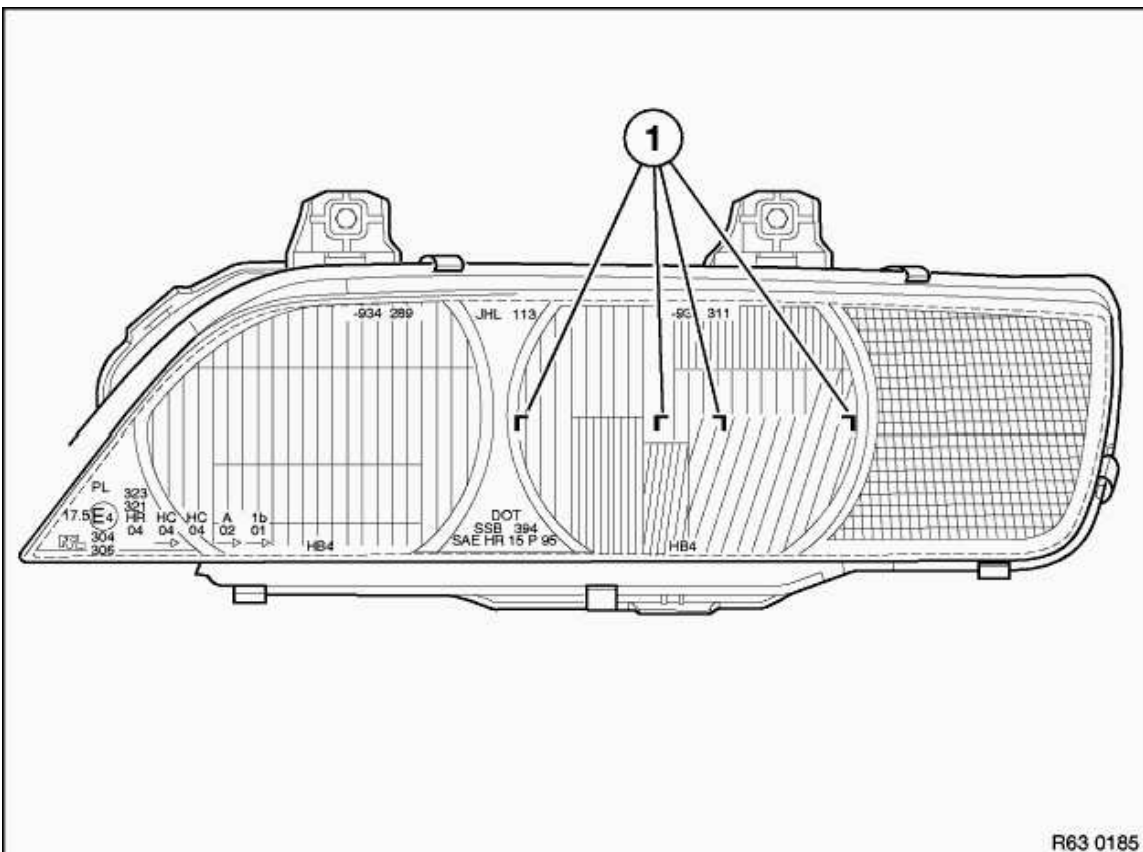

Left headlights in direction of travel:

Marking angles are provided on the reflector.

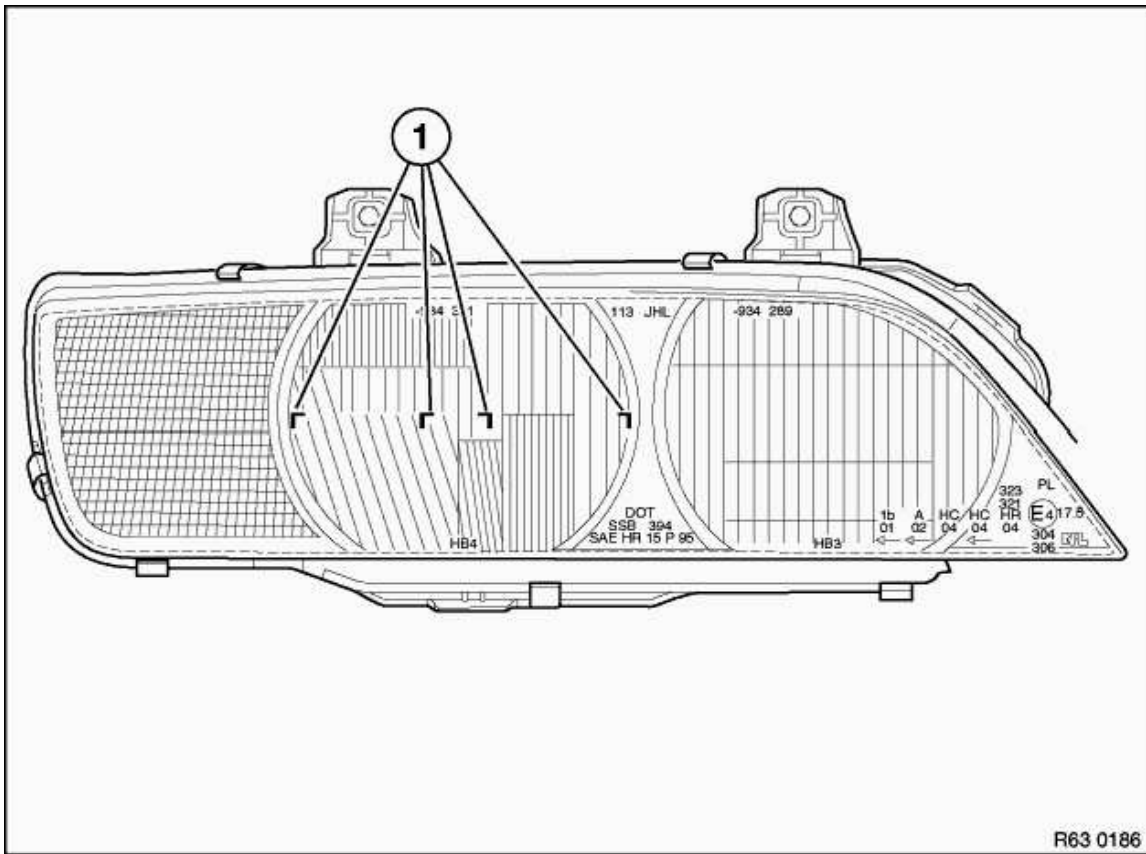

Left headlight in direction of travel:

Marking angles are provided on the reflector.

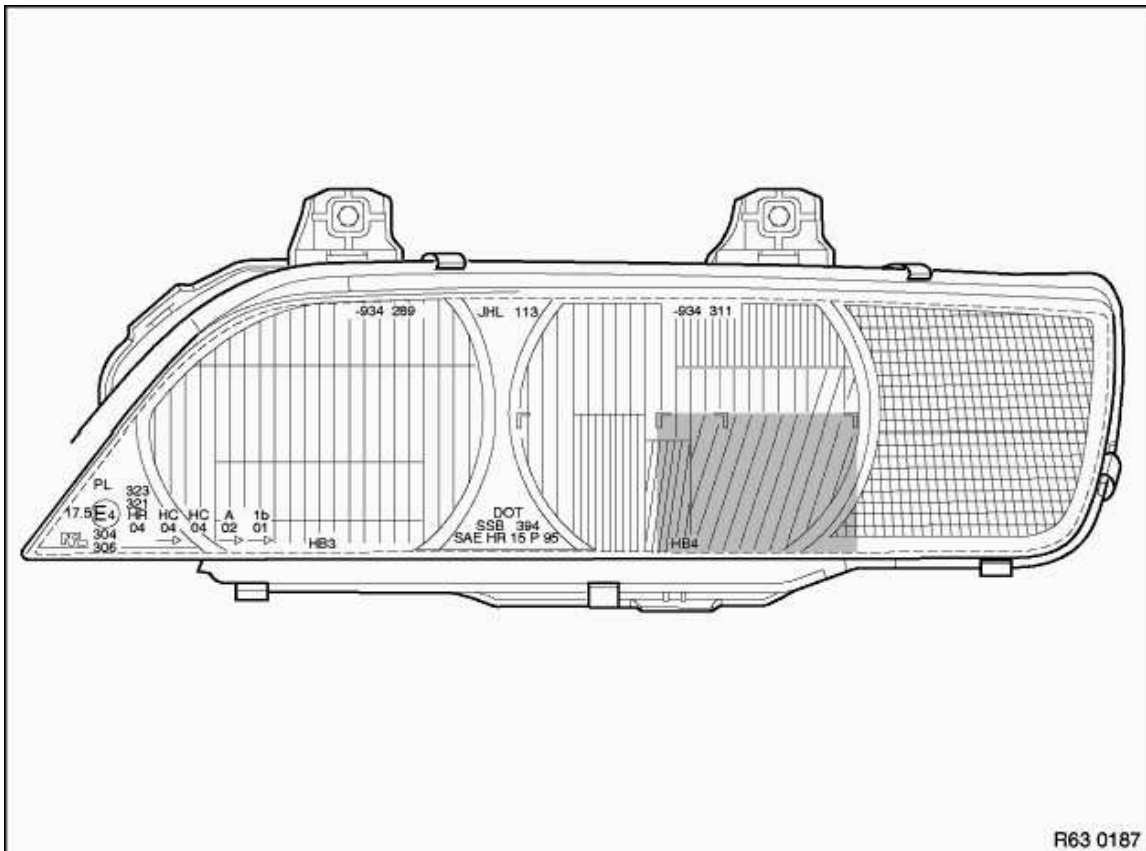

Left headlight in direction of travel:

Covered area of a LHD vehicle in a RHD country.

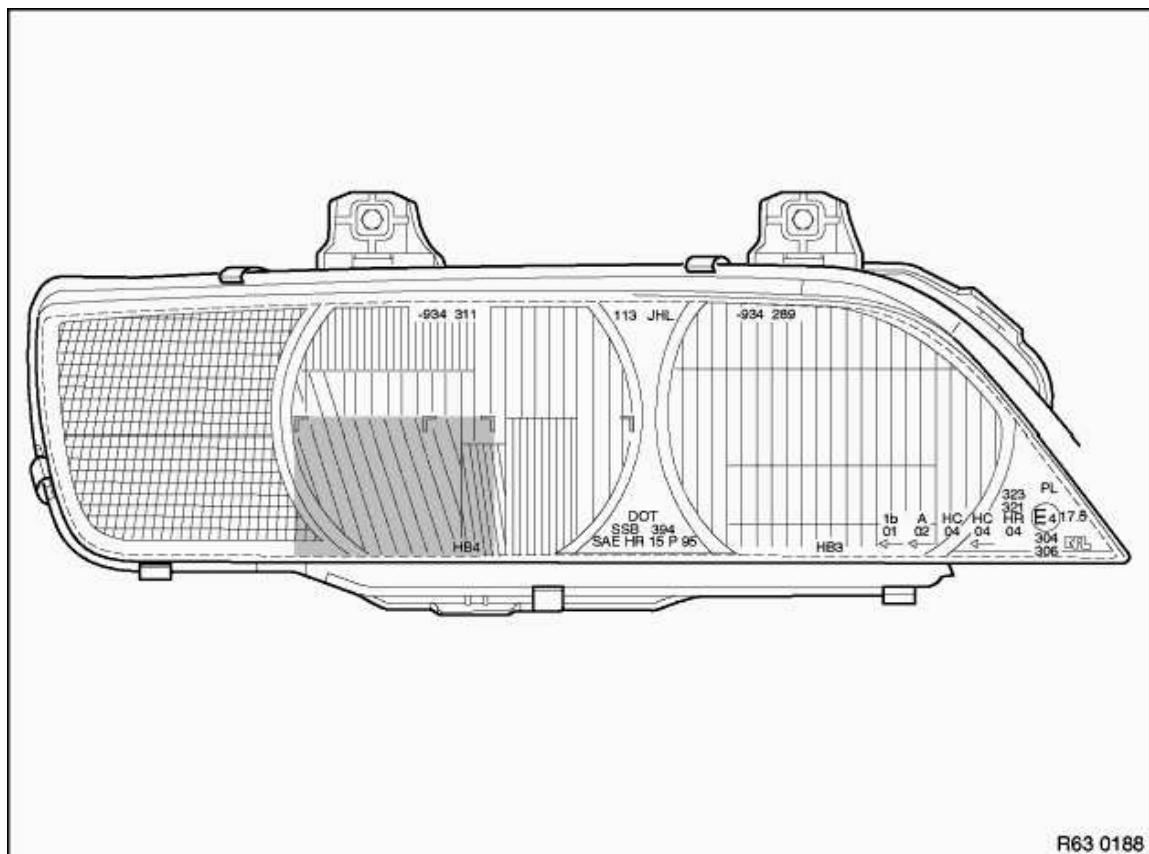

Right headlight in direction of travel:

Covered area of a LHD vehicle in a RHD country.

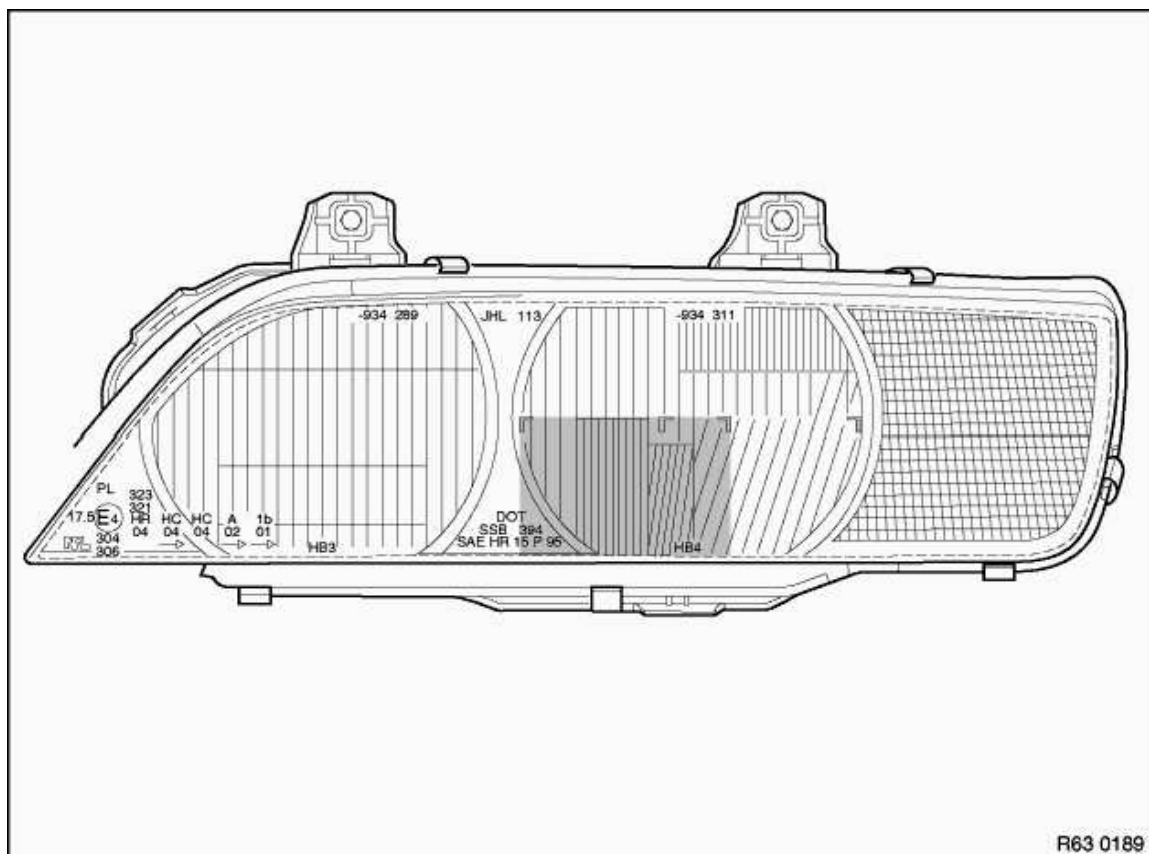

Left headlight in direction of travel:

Covered area of a RHD vehicle in a LHD country.

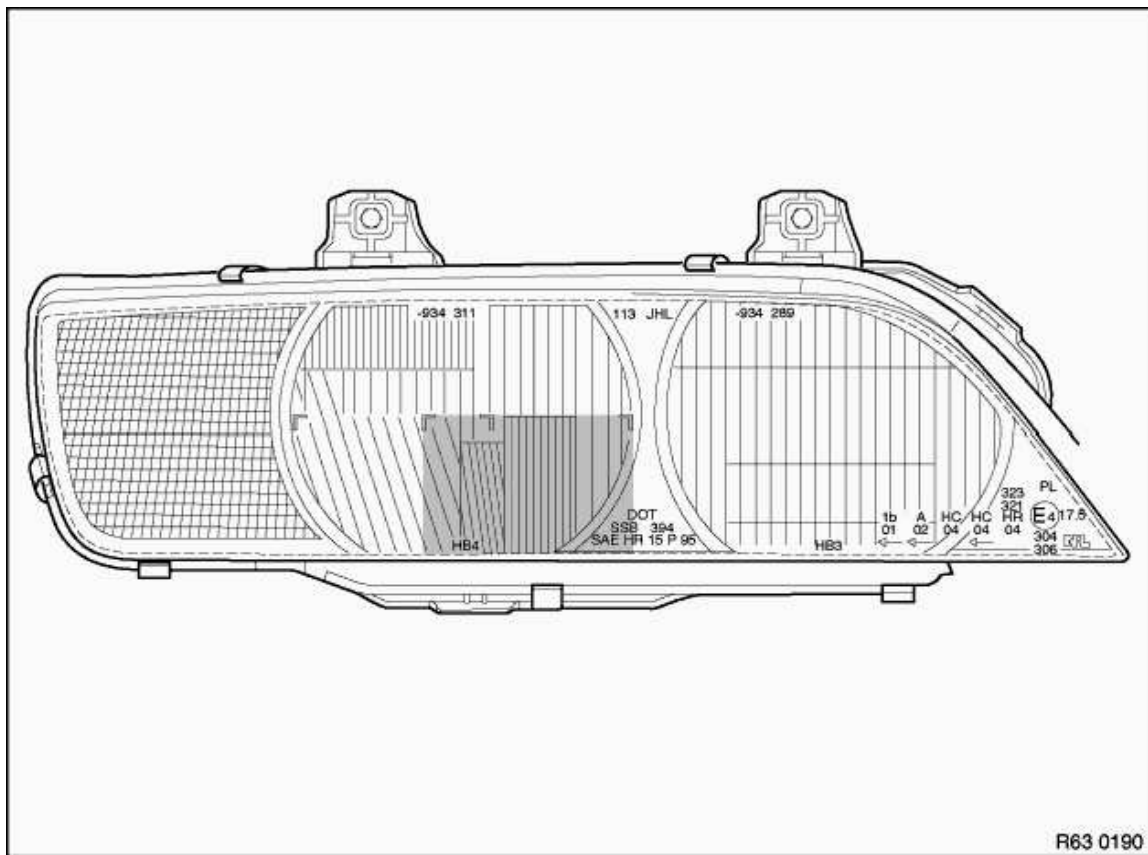

Right headlight in direction of travel:

Covered area of a RHD vehicle in a LHD country.