

Preliminary tasks are described in Disassembling and assembling cylinder head.

Remove valve stem seal with special tool 11 1 480.

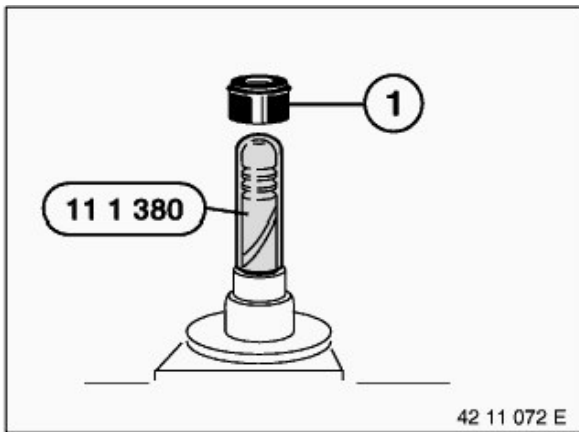
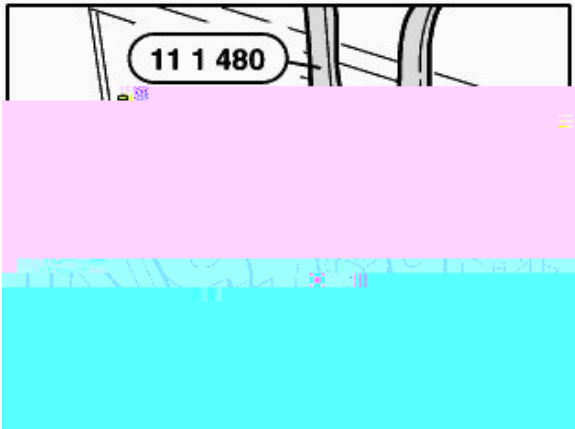

S50 B30

Valve stem diameter 7 mm:

Installation:

Lubricate valve stem with oil and insert valve.

Fit special tool 11 1 380.

Coat new valve stem seal (1) with oil and install.

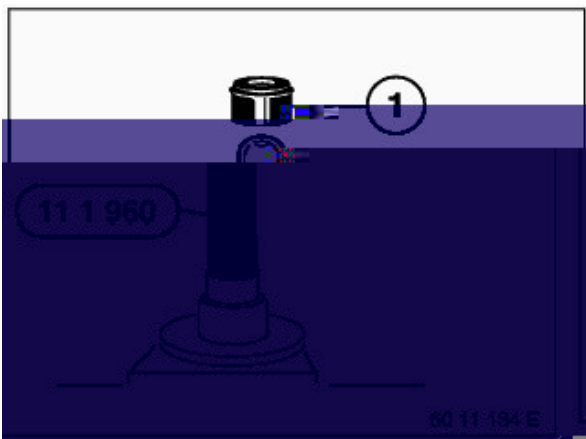

S50 B32 and S54

Valve stem diameter 6 mm:

Installation:

Lubricate valve stem with oil and insert valve.

Fit special tool 11 1 960.

Coat new valve stem seal (1) with oil and install.

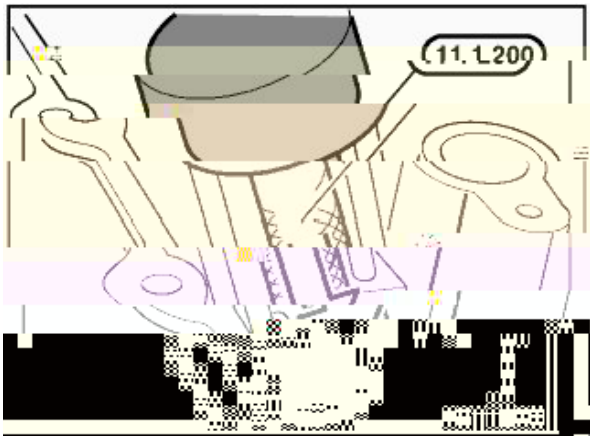

Note:

Special tool 11 1 200 is used for valve stem diameters 6 mm and 7 mm.

Installation:

Press valve stem seal firmly home by hand with special tool 11 1 200.