

(piston removed)

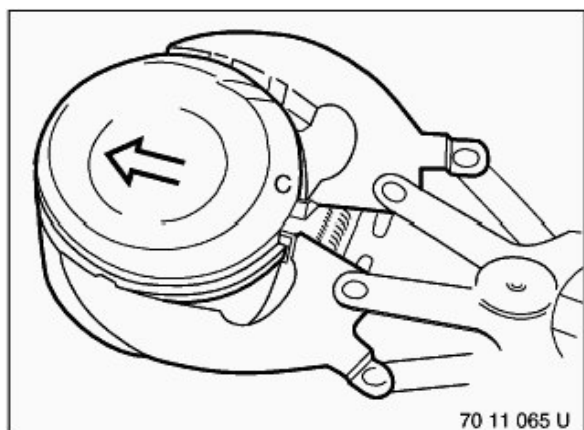

Remove piston rings with piston-ring compressing pliers.

*Note:*

It might not be possible to find the identification on used piston rings.

Put aside piston rings in correct sequence and installation position.

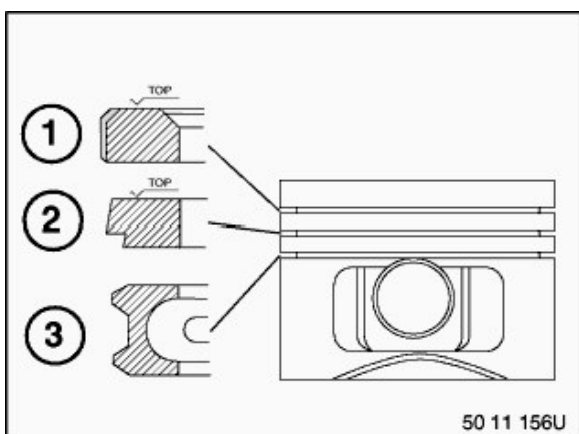

*Installation:*

Insert piston rings with the word "TOP" facing piston crown.

- 1) Plain compression ring "TOP"
- 2) Tapered compression ring "TOP"
- 3) Slotted oil-scraper ring with rubber-lined spring

Offset the contact points of the piston rings by approx. 120° to each other but do not position above the piston pin boss.

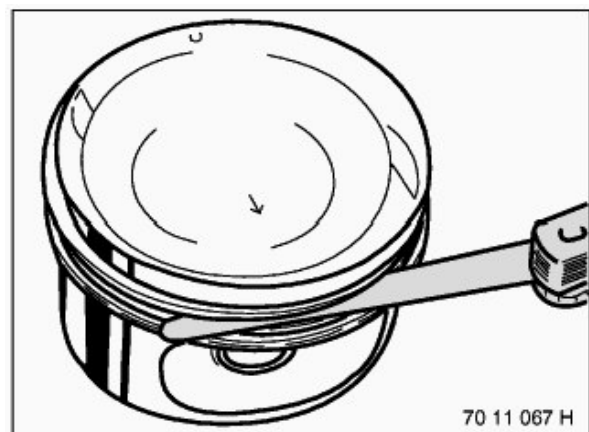

Measure axial play.

Axial clearance.

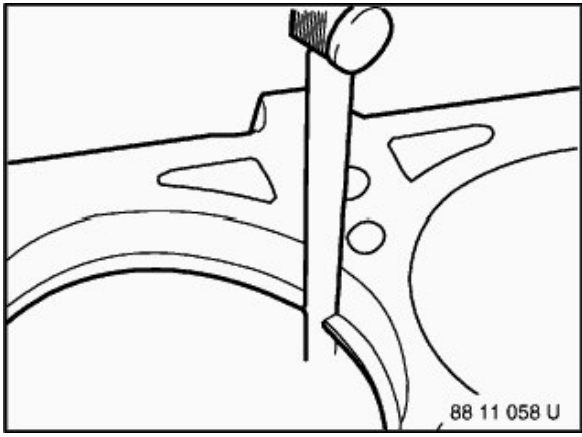

Measure end clearance.

End clearance.